



*Endless water for a variety
of workplace environments*

Quench Q5

FREESTANDING AND COUNTERTOP SERIES

- Appreciate refreshing filtered water at any time in any environment
- Choose robust, large capacity model that delivers a great user experience
- Feel protected from contamination with carbon filtration and UV light technology





Quench Q5

The Quench Q5 series are robust, high capacity water coolers that serve a range of workplaces from professional offices to schools and warehouses. The generous dispenser size provides easy access to endless filtered chilled and hot water. And the advanced filtration technologies, in-tank UV light, and antimicrobial surface protection offer distinct water quality assurance.



Built for a variety of environments

- Large capacity with 1.6 gallon cold tank in freestanding model
- Tall freestanding model with comfortable dispense height
- Rugged paddle dispensing and hot water safety feature
- 1 Micron carbon filtration with lead reduction
- LED Ultraviolet light to maintain water quality
- Antimicrobial surface protection
- Bottle-filling with 11" dispense height in freestanding model
- Countertop model fits nicely under cabinets

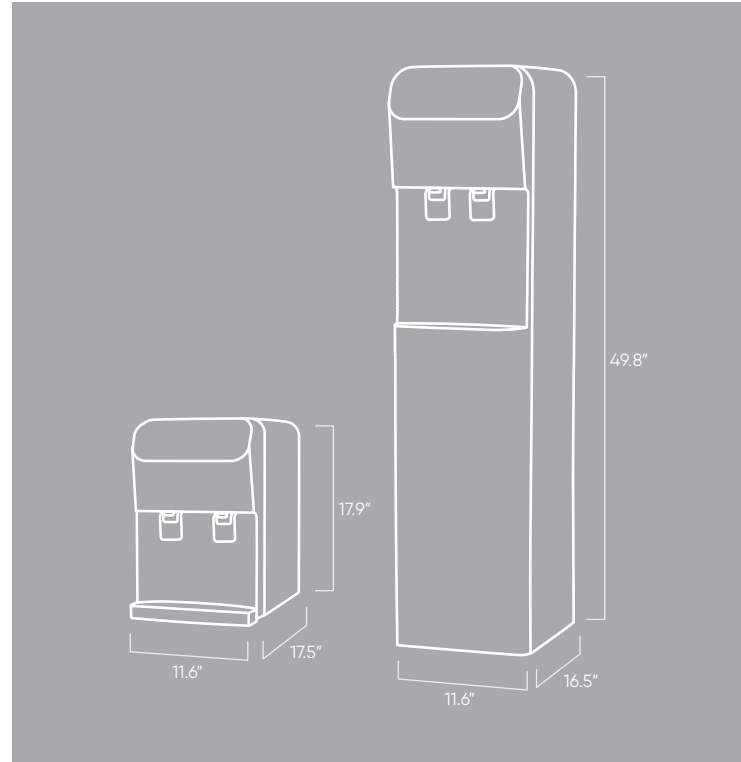

Specifications

QUENCH Q5 FREESTANDING

Dimensions	49.8" h x 11.6" w x 16.5" d/ 127 cm h x 30 cm w x 42 cm d
Weight	60 lbs/28 kg
Cold Tank Capacity	1.6 gallons/6.1 liters
Hot Tank Capacity	0.7 gallons/2.7 liters
Dispensing Area Height	11.2"
Rated Voltage/Frequency	120V/60Hz
Power Consumption	1.6kWh / 24 hours
Recommended Water Pressure	40 – 60 psi
Model Number	Q5FS

QUENCH Q5 COUNTERTOP

Dimensions	17.9" h x 11.6" w x 17.5" d/ 46 cm h x 30 cm w x 45 cm d
Weight	49 lbs/23 kg
Cold Tank Capacity	1.0 gallons/3.8 liters
Hot Tank Capacity	0.4 gallons/1.4 liters
Dispensing Area Height	8.2"
Rated Voltage/Frequency	120V/60Hz
Power Consumption	1.1 kWh/24 hours
Recommended Water Pressure	40 – 60 psi
Model Number	Q5CT



630 Allendale Road, Suite 200
King of Prussia, PA 19406
Phone: 888.877.0561

<https://quenchwater.com>

© 2018 Quench. All rights reserved. Q5-001-NOV18

